

January 2010



ROUTE-MASTER Fieldbus Device Couplers are available in field-mount enclosures complete with cable glands (aluminum enclosure shown), or as DIN-rail mount units.

ROUTE-MASTER uses a space-efficient rack-mount design to provide redundant power to up to eight intrinsically-safe segments.

Description

The ROUTE-MASTER Fieldbus System uses a patented split-architecture design to deliver the highest segment current to a hazardous area of ANY intrinsically-safe FOUNDATION fieldbus™ system. ROUTE-MASTER provides 350mA per segment—enough to power 16 fieldbus devices (20mA each) at 500m (1,500ft)—while remaining intrinsically-safe for hydrogen-risk areas at the individual spur connection. The system is comprised of a modular Power Supply/Conditioner Rack (RM100) combined with one, or multiple, ROUTE-MASTER Fieldbus Device Couplers (RMA100 or RMA100C). Featuring integral surge protection, the 19-inch Power Supply/Conditioner Rack provides redundant, galvanically-isolated and conditioned DC power for up to eight fieldbus segments. The RMA100 and RMA100C Device Couplers are available in models that handle four to 20 fieldbus devices.

Protect Segments from Spur Faults

ROUTE-MASTER Device Couplers provide electronic and fully auto-resetting spur short-circuit protection that prevent segment failure caused by single device faults. Utilizing a “FoldBack” technique, any spur that attempts to draw more than approximately 48mA is automatically switched off and not permitted any current flow until the fault is removed. This is a significant advantage over “current-limiting” designs on competing units which hold a fault permanently on the segment at a higher-than-normal current level. This often results in segment failure by overloading the segment power supply. With removal of the short, the spur is automatically reconnected to the fieldbus segment.

Features

- **Unique split-architecture design.** Allows an industry best 350mA for I.S. segments and allows the full 1900m per segment/120m per spur.
- **Connect directly to FISCO or Entity devices.** The ATEX-approved version Device Couplers (RMA100C) can be installed in IIB or IIC areas connecting FISCO or Entity devices.
- **Reduce commissioning delays.** ROUTE-MASTER Device Couplers feature patented* “Automatic Segment Termination” that eliminates the most common installation problem: segment failure from under or over termination, and assures local parts of a segment will continue to function if remote parts are accidentally disconnected. (The Manual Termination (-MT) option is also available for users who prefer manual termination.)
- **Speeds diagnostics and device configuration.** Diagnostic LEDs on the Device Couplers positively indicate status of spur power, any spur short circuits, and status of auto termination. The front panel features convenient connections for a fieldbus hand-held communicator.
- **High-availability power supply.** The RM100 Power Conditioner combines redundant DC power per segment with highly reliable passive conditioning to help assure an exceptionally reliable fieldbus segment.

* United States Patent No. 7,355,438 and Great Britain No. 2,407,237

Certifications



Check the listing on Page 6 for certification details.

All product names are registered trademarks of their respective companies.

RM100

ROUTE-MASTER® Fieldbus System (Intrinsically-Safe Installations)

Complete Intrinsically-Safe Fieldbus System

The ROUTE-MASTER Fieldbus System delivers intrinsically-safe segment power (350mA) and connects between a FOUNDATION fieldbus H1 card mounted in a safe area and fieldbus devices mounted in a hazardous area.

Fieldbus Segment Power Conditioning and Isolation

The ROUTE-MASTER's 19-inch Power Supply/Conditioner (RM100) converts an AC power input to up to eight fully-isolated DC channels (Figure 1). A DC Regulator Card (RM103B) controls the voltages of each of the individual channels. A second DC Regulator Card may be added to the rack to provide redundancy, load-sharing and hot-swap capabilities.

Trunk Isolator Modules (up to eight per rack) provide passive fieldbus conditioning, systems-side isolation and I.S. current-limiting for each fieldbus segment. The output from each Trunk Isolator Module (RM102B) is a galvanically-isolated, redundantly-powered, passively-conditioned and intrinsically-safe fieldbus trunk that can be connected into a hazardous area. No I.S. ground is required.

The RM102B Trunk Isolator Module provides dual outputs from the same H1 segment input, with each providing independent I.S. current-limiting. This technique minimizes irrecoverable voltage drop and maximizes the power available in the field.

Each trunk is available for connection to separate RMA100 and RMA100C Device Couplers, which remain part of the same segment. When used in this way, the individual trunk currents per leg create voltage drop only in that leg, avoiding the losses which would be imposed if all devices were powered from a single trunk.

Because the Trunk Isolator Module has independent I.S. power limitation per trunk, each trunk is considered as a separate I.S. circuit and there are no complications for use in a hazardous area.

The dual trunk configuration allows 16 devices with 500m (1640ft) cable, even in areas classified as IIC/Groups A and B. The use of both trunks in this way is optional, and single trunk connection may be preferred where total cable length is short and device numbers and/or total current draw within the segment is low. In single trunk applications, a local terminator (TRK-TERM) should be fitted to the unused channel of the Trunk Isolator Module.

Note: Trunk Isolator Modules do not power the systems side of a H1 card. Specify the RM110 PowerTray if this function is required.

Figure 1. RM100 Power Conditioner Rack Connections.

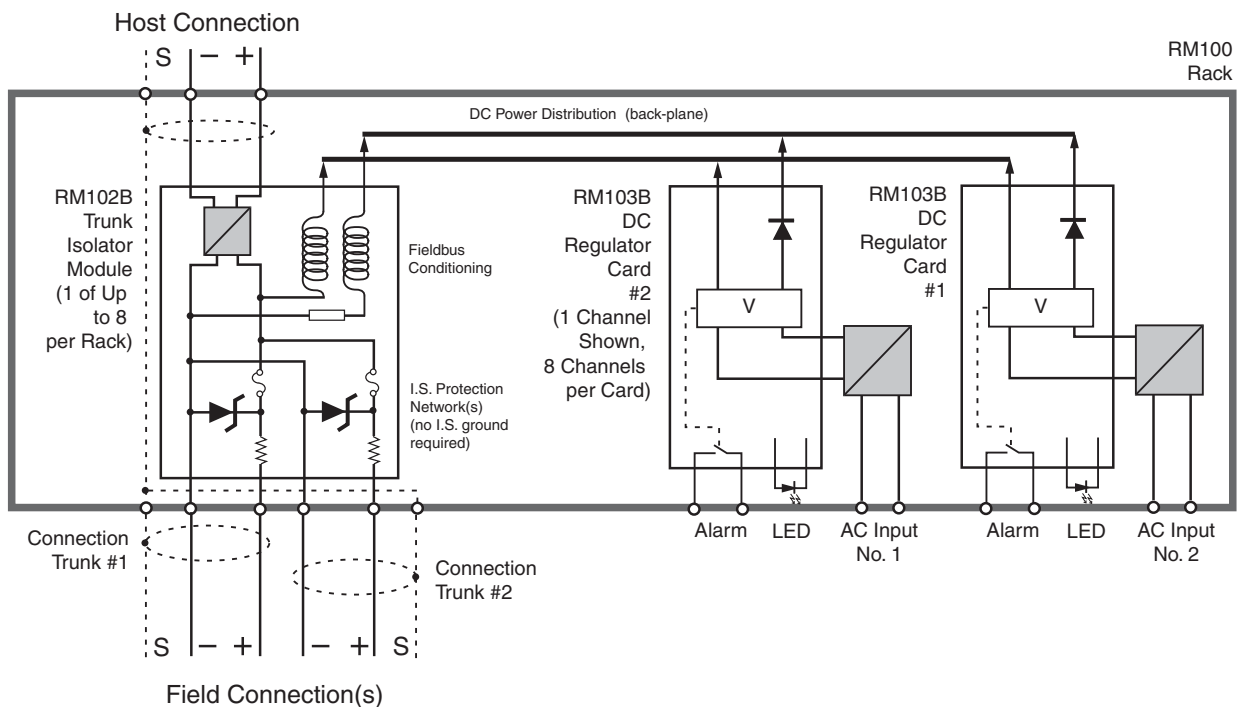

Fieldbus Device Couplers

The intrinsically-safe trunk powered by the ROUTE-MASTER's Trunk Isolator Module (RM102B) is available for connection to one (or more) ROUTE-MASTER Device Couplers. Device Couplers can be mounted in the field or back-of-panel.

ROUTE-MASTER Device Couplers offer environmental and functional advantages that simplify fieldbus segment design.

Environmental Advantages—ROUTE-MASTER Device Couplers can be ordered in ready-to-install, field-mount enclosures designed for applications in rugged and hazardous field conditions. Options include aluminum (painted blue), GRP (Glass Reinforced Polyester) and stainless steel enclosures. All offer IP66 protection. Standard cable glands

are nickel-plated brass, and can be ordered for use with un-armored or armored cable. Compound seal glands (for cable with inter-core spaces, i.e., unfilled cable), and quick-connect plugs and sockets are also available.

Functional Advantages—MooreHawke Device Couplers offer functional advantages over the competition. This includes our unique short circuit protection (see Page 1) and patented "Automatic Segment Termination", which also enables easy extension of the segment through additional device couplers without re-termination issues. The Manual Termination (-MT) Option is available for users who prefer manual termination. Other advantages include convenient field test points for hand-held communicators.

Figure 2A. The ATEX approved, FISCO compatible ROUTE-MASTER features Device Couplers that mount directly in IIC areas (Model RMA100C) and delivers 350mA per segment into hazardous locations.

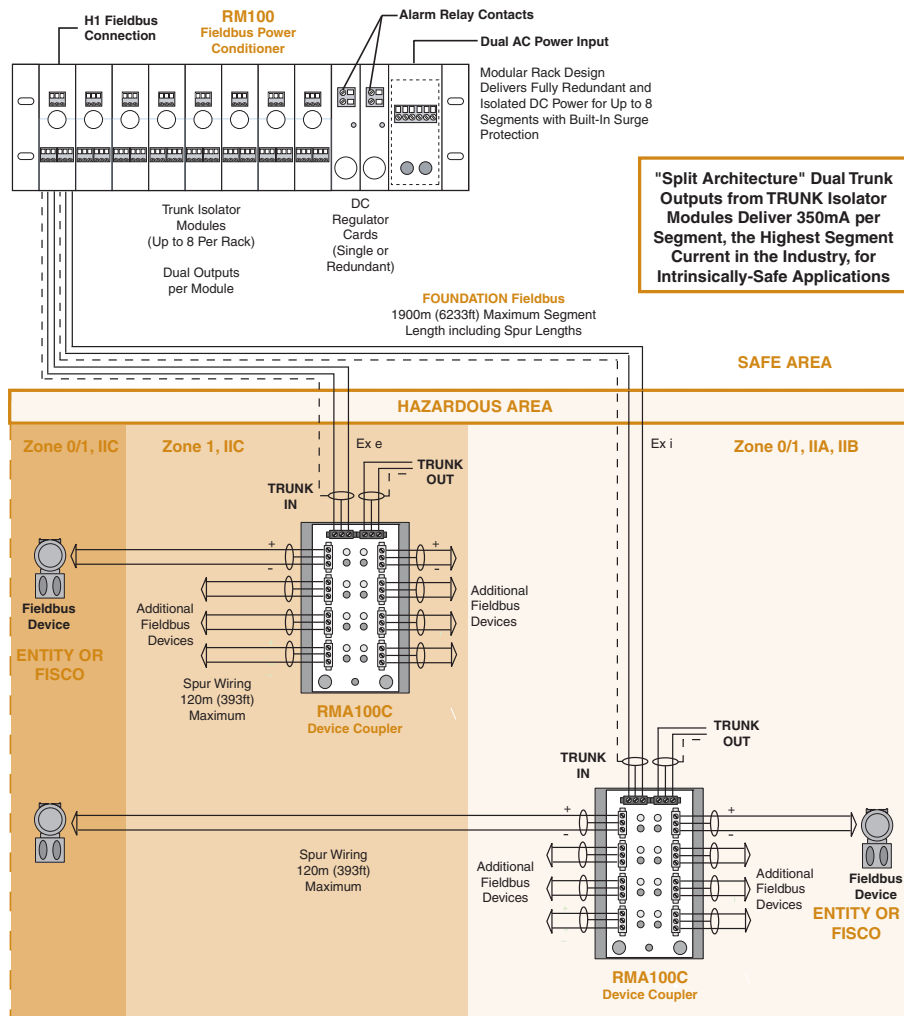

RM100

ROUTE-MASTER® Fieldbus System (Intrinsically-Safe Installations)

Figure 2B. FM and ATEX approved ROUTE-MASTER systems with RMA100 Device Couplers mount in a IIB location, and directly connect to devices in IIC locations to deliver 350mA per segment into hazardous areas/locations.

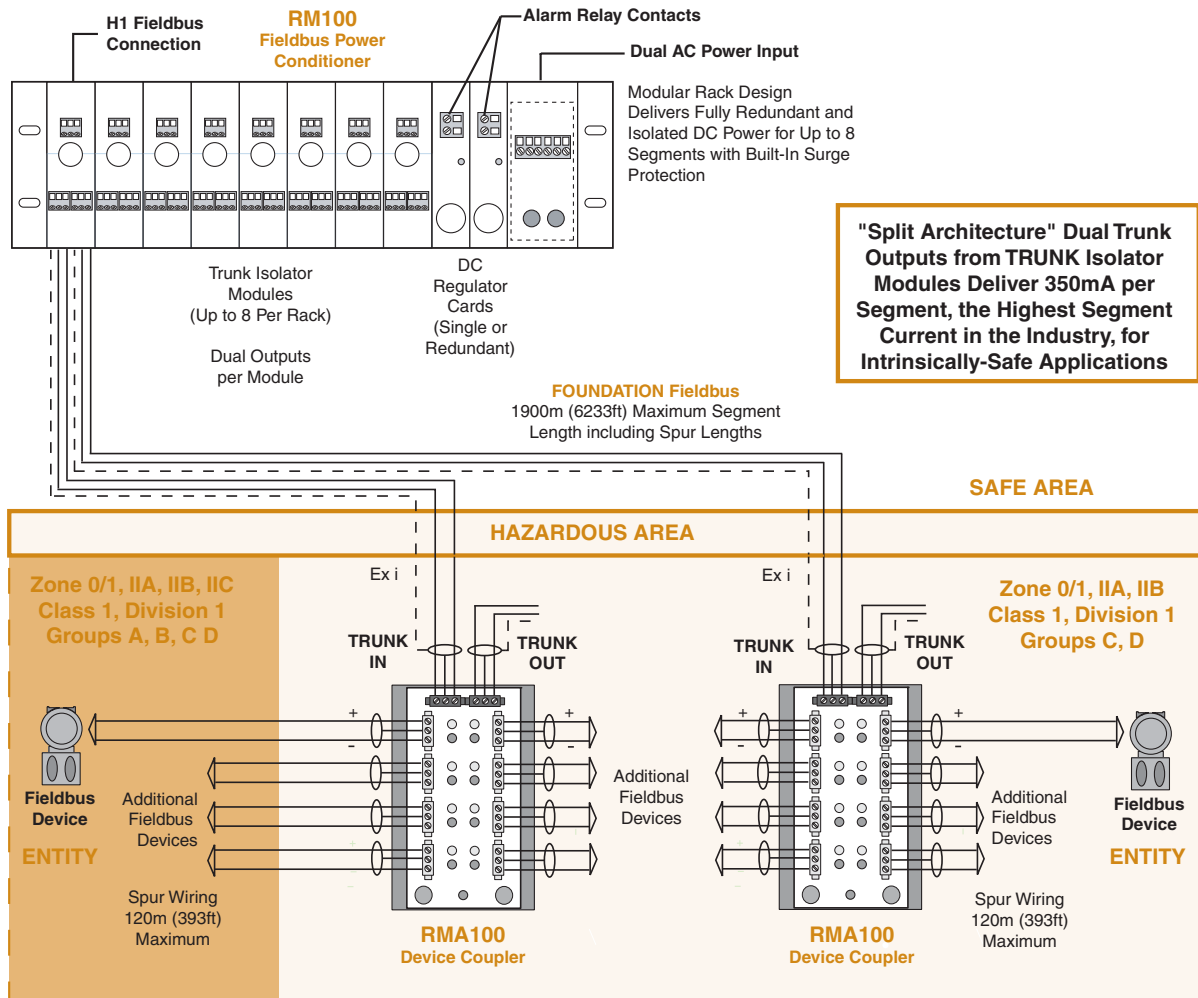

Specifications

RM100 ROUTE-MASTER Fieldbus Power Supply/Conditioner Rack

<p>Communications FOUNDATION Fieldbus™ (H1) to IEC61158-2</p> <p>Performance Rack Capacity: Up to 8 Trunk Isolator Modules (RM102B); One or two DC Regulator Cards (RM103B) Supply Voltage: 115Vac or 230Vac, 50/60Hz (not field selectable) Output: 18.65V (no load), 350mA per segment Power Dissipation: 35W, fully-loaded, 8 channels</p>	<p>Performance (continued) Fault Power: 250W, all channels shorted MTTF (MIL HDBK-217): Segment with Single DC Regulator Card, 66 years; Segment with Dual DC Regulator Cards, 468 years Trunk Isolator Module, 510 years Alarm Action: Volt-free Contact Closure (rated at 250Vac, 0.5A, 100VA) Terminals: Screw-clamp terminals, 0.8-2.5mm²/12-24AWG</p>	<p>Indicators One GREEN LED per DC Regulator Card indicates normal operation</p> <p>Ambient Conditions Operating: -20°C to +60°C (-4°F to +140°F) Storage: -40°C to +85°C (-40°F to +185°F) Relative Humidity: 0-95%, non-condensing Surge Protection: 5,000W/1msec RFI/EMI Immunity: 10V/m@80-1000MHz, 1kHz AM (IEC61326)</p>
---	--	---

RMA100 and RMA100C Fieldbus Device Couplers

<p>Communications FOUNDATION Fieldbus™ (H1) to IEC61158-2</p> <p>Performance Voltage Rating: V_{max}: 18.65V V_{min}: 11V Maximum Quiescent Current: RMA104/RMA104C: 9mA@18.65V; 5mA@12V RMA108/RMA108C: 13mA@18.65V; 9mA@12V RMA10X/RMA10XC: 15mA@18.65V; 11mA@12V (4mA lower with -MT option) Spur Output Voltage (No Load): RMA100/RMA100C: V<V_{in}<18.65V; RMA100: 10.4V<V_s<18.5V RMA100C: 10.5V<V_s<16V</p>	<p>Performance (continued) Max. Spur Output Current: I_{s_{lim}} = 48mA Spur Short Circuit Load: I_{s_{sc}}: 2mA typical, 5mA maximum Maximum Voltage Drop Trunk IN to OUT: V_{dt}: 0.5V</p> <p>Indicators Spur: GREEN (normal) RED (fault) Auto-Terminator: YELLOW LED is on when auto-termination is activated</p> <p>Terminals Type: Removable terminals with screw-clamp retaining screws Wire Size: Handles sizes between 0.8-2.5mm²/12-24AWG</p>	<p>Cable Glands (Device Couplers with Enclosures) Type: Armored/Unarmored Material: Nickel-plated brass</p> <p>Ambient Conditions Operating: -40°C to +70°C (-40°F to +158°F) Storage: -40°C to +85°C (-40°F to +185°F) Relative Humidity: 0-95%, non-condensing Surge Protection: EN61326, EN6100-4-5 1KV (1.2/50 usec impulse) differential mode protection RFI/EMI Immunity: 10V/m@80-1000MHz, 1kHz AM (IEC61326)</p>
---	---	---

Ordering Information (Continued on Page 6)

RM100 ROUTE-MASTER Fieldbus Power Supply/Conditioner Rack

Rack	No. of Trunk Isolator Modules	No. of DC Regulator Cards	Power	Optional H1 Interface
RM100 ROUTE-MASTER 19-Inch Power Conditioner Rack with Trunk Isolator Module(s) and DC Regulator Card(s) for Intrinsically-Safe Applications	-1 Trunk Isolator Module -2 Trunk Isolator Modules -3 Trunk Isolator Modules -4 Trunk Isolator Modules -5 Trunk Isolator Modules -6 Trunk Isolator Modules -7 Trunk Isolator Modules -8 Trunk Isolator Modules	-1 DC Regulator Card -2 DC Regulator Cards (Redundant)	-A 115Vac -B 230Vac	-Y Yokogawa Connector Panel

When ordering, specify: Rack -No. of Trunk Isolator Modules -No. of DC Regulator Cards - Power
Model number example: **RM100-8-2-A**
 (Rack with 8 Trunk Isolator Modules, 2 DC Regulator Cards and 115Vac Power)

RM100

ROUTE-MASTER® Fieldbus System (Intrinsically-Safe Installations)

Ordering Information (Continued from Page 5)

RMA100 and RMA100C Fieldbus Device Coupler

Unit	Mounting/Enclosure Type	No. of Spurs	Gland/Connector Type	Gland Entry Size
RMA1 ROUTE-MASTER Device Coupler for Intrinsically-Safe Applications	0 DIN-Rail Mount (No enclosure)	FM and ATEX Approved for Mounting in IIB areas with Spurs in IIA, IIB or IIC Areas (ENTITY Only): 4 Fieldbus Spurs 8 Fieldbus Spurs X 10 Fieldbus Spurs ATEX FISCO or ENTITY Approved for Mounting in IIA, IIB or IIC Areas: 4C Fieldbus Spurs 8C Fieldbus Spurs XC 10 Fieldbus Spurs	Not Applicable	-DIN (No cable glands) Universal DIN-style en- closure mounts on 32mm (EN50035) G-type and 35mm (EN50022) Top Hat DIN-rails
	5 Standard Aluminum (Blue), Solid Cover, IP66 Enclosure 6 Standard Aluminum (Blue), Clear Cover, IP66 Enclosure 4 Stainless Steel 316, IP66 Enclosure with E-Z vertically remov- able lid and bottom entry cable gland plate	FM and ATEX Approved for Mounting in IIB areas with Spurs in IIA, IIB or IIC Areas (ENTITY Only): 4 Fieldbus Spurs 8 Fieldbus Spurs X 10 Fieldbus Spurs Y 20 Fieldbus Spurs ATEX FISCO or ENTITY Approved for Mounting in IIA, IIB or IIC Areas: 4C Fieldbus Spurs 8C Fieldbus Spurs XC 10 Fieldbus Spurs YC 20 Fieldbus Spurs	-A Unarmored Cable Glands (standard) -B Armored Cable Glands -C Compound Seal Cable Glands -D No Cable Glands -E M12 Turck Eurofast™ Sockets -F 7/8-in Turck Minifast™ Sockets NOTES: 1. Gland/connector selection is for all entry ports. 2. Choices "-E" and "-F" have male sockets for "Trunk In" and female sockets for "Trunk Out" and "Spurs". 3. Weatherproof seals are provided for all glands, but not sockets.	GLAND ENTRY SIZE FOR: -O (standard) Unarmored Cable (7.5-11.9mm O.D.); Armored Cable (9.5-16.0mm O.D.) -S Unarmored Cable (3.0-8.0mm O.D.); Armored cable (5.5-12.0mm O.D.)
	2 Stainless Steel 316, IP66 Enclo- sure 3 GRP (Glass Reinforced Polyester), Blue IP66 Enclosure <div style="border: 1px solid black; padding: 5px; width: fit-content;">NOTE: Device coupler with stainless steel 316 enclosure (4) and 20 field- bus channels (Y) is composed of two 10-channel couplers (X) mounted in the enclosure.</div>	FM and ATEX Approved for Mounting in IIB areas with Spurs in IIA, IIB or IIC Areas (ENTITY Only): 4 Fieldbus Spurs 8 Fieldbus Spurs X 10 Fieldbus Spurs ATEX FISCO or ENTITY Approved for Mounting in IIA, IIB or IIC Areas: 4C Fieldbus Spurs 8C Fieldbus Spurs XC 10 Fieldbus Spurs		

When ordering, specify: Unit • Mounting or Enclosure Type • Number of Spurs -Gland/Connector Type -Gland Entry Size
Model number example: RMA158-A-O
 (8-Spur RMA100 Device Coupler in Aluminum Enclosure with Cable Glands for Unarmored Cable)
 RMA154C-A-O
 (4-Spur RMA100C Device Coupler in Aluminum Enclosure with Cable Glands for Unarmored Cable)

Accessories:

Description	Model Number
Trunk Terminator	TRK-TERM***
Surface Mounting Bracket for RM100 Rack*	RMB-001
Spare DC Regulator Card	RM103B
Spare Trunk Isolator Module	RM102B
Power Tray (see Data Sheet for details)**	RM110-8-S

* One pair provided with each RM100 Rack. This option is for retrofit or replacement.
 ** Required for use with Emerson, ABB, Honeywell systems. Consult the factory for other
 manufacturer's systems that may require this accessory.
 *** May be required per RM102B Trunk Isolator Module when used in single-trunk mode. Trunk
 termination may also be performed by the Host or the RM110 Power Tray.

Entity Systems and Cable Parameters

A ROUTE-MASTER System with a model RMA100 Device Coupler can be installed in a IIA or IIB location, but can be connected to devices in IIC locations (Figure 2B). As an Entity System, it is necessary to demonstrate that the design does not exceed the specified (Entity) parameters for the location.

The unique split-architecture design of RM100 means that this calculation need only be completed once and will cover the entire plant installation.

First, calculate the capacitance of a worst case trunk cable and spur; 120m of the chosen cable plus an FF816 device. This will certainly be less than the 262nF allowable in IIC.

Second, calculate the L/R ratio for the chosen cable (most manufacturers only quote inductance and resistance values on their datasheets). This should calculate out to around 25 L/R or so.

Third, document these calculations with an annotation that no spur can be longer than 120m. Also document that the calculations include the longest trunk. Finally, document that no other type of cable is being used in these I.S. fieldbus networks.

Note that each spur cable (and also trunk cable in dual-trunk configuration) is a separate I.S. network. Parameters for these cables are not added together.

Combination FISCO and Entity Systems

As shown in Figure 2A, the RMA100C Device Coupler can receive FISCO or Entity devices from up to 120 meters with the device coupler located in IIA, IIB or IIC. Note that if placed in IIC, the trunk cable must be Ex e rated. All spur

cable is Ex i regardless of RMA100C location. If FISCO approved Ex i cable is used with the FISCO device, then no spur cable parameters need be calculated. If entity devices are to be connected then calculate the cable parameters for the longest trunk and longest spur. This calculation of the longest trunk and the longest spur (120m) would then be sufficient to cover the entire site, so that no further entity calculations need to be performed.

Certifications



Sira (ATEX)

Certificate No: 00ATEX2090X

RM100 Rack:

II (1) G [EEx ia] IIB
T_a = -20 to +60°C

RMA100 Device Coupler:

II 1 G EEx ia IIB T4
EEx [ia] IIC T4
T_a = -40 to +70°C

RMA100C Device Coupler:

II 1 G EEx ia IIB T4
II 2 (1) G EEx me [ia] IIC T4
T_a = -40 to +70°C



Factory Mutual (cFmus) US/Canada

Certificate No. 3009466

RM100 Rack: Associated apparatus located in non-hazardous location with intrinsically-safe connections for Class I, Division 1, Groups C and D hazardous locations when installed in accordance with Control Drawing HCGFB-902

RMA100 Device Coupler: Intrinsically-safe apparatus for installation in Class I, Division 1, Groups C and D with intrinsically-safe connections for Class I, Division 1, Groups A, B, C and D hazardous locations when installed in accordance with Entity Requirements and Control Drawing HCGFB-902



CE Conformant – EMC Directive 89/336/EEC EN61326

Permissible ENTITY Cable Parameters for RM100 Fieldbus System:

Gas Group	Capacitance (nF)	AND	Inductance (mH)	OR	L/R ratio (µH/Ohms)
IIA/Group D	6390 (Trunk or Spur)		0.412 (Trunk plus Spurs)		72
IIB/Group C	1600 (Trunk or Spur)		0.206 (Trunk plus Spurs)		36
IIC/Groups A B	262 (Spur only, NA for TRUNK)		0.150 (Trunk plus Spurs)		30

Typical Type A (Screened Twisted Pair) Cable Data*:

Type	Capacitance (nF/km)	Inductance (mH/km)	Resistance (Ohm/km/Core)	L/R Ratio (µH/ohm)	Notes
Turck 490/493	100	0.48	21.4	11.2	18AWG, Non-Armored
Turck 492	100	0.62	24.1	12.85	18AWG, Armored
Belden 3076F	78	0.617	23.7	13	18AWG, Non-Armored
Belden 3077F	143	0.65	55.6	6	22AWG, Non-Armored
Kerpen 727900019	115	0.66	26.5	12.5	0.75mm ² , Non-Armored
Kerpen 7279B0015	115	0.46	18.4	12.5	1.0mm ² , Non-Armored

* Moore Industries is not responsible for specification changes made to third-party products. Please review the latest cable data from each manufacturer.

RM100

ROUTE-MASTER® Fieldbus System (Intrinsically-Safe Installations)

Figure 3. RM100 Power Conditioner Rack and RMB-001 Surface Mounting Bracket Installation Dimensions.

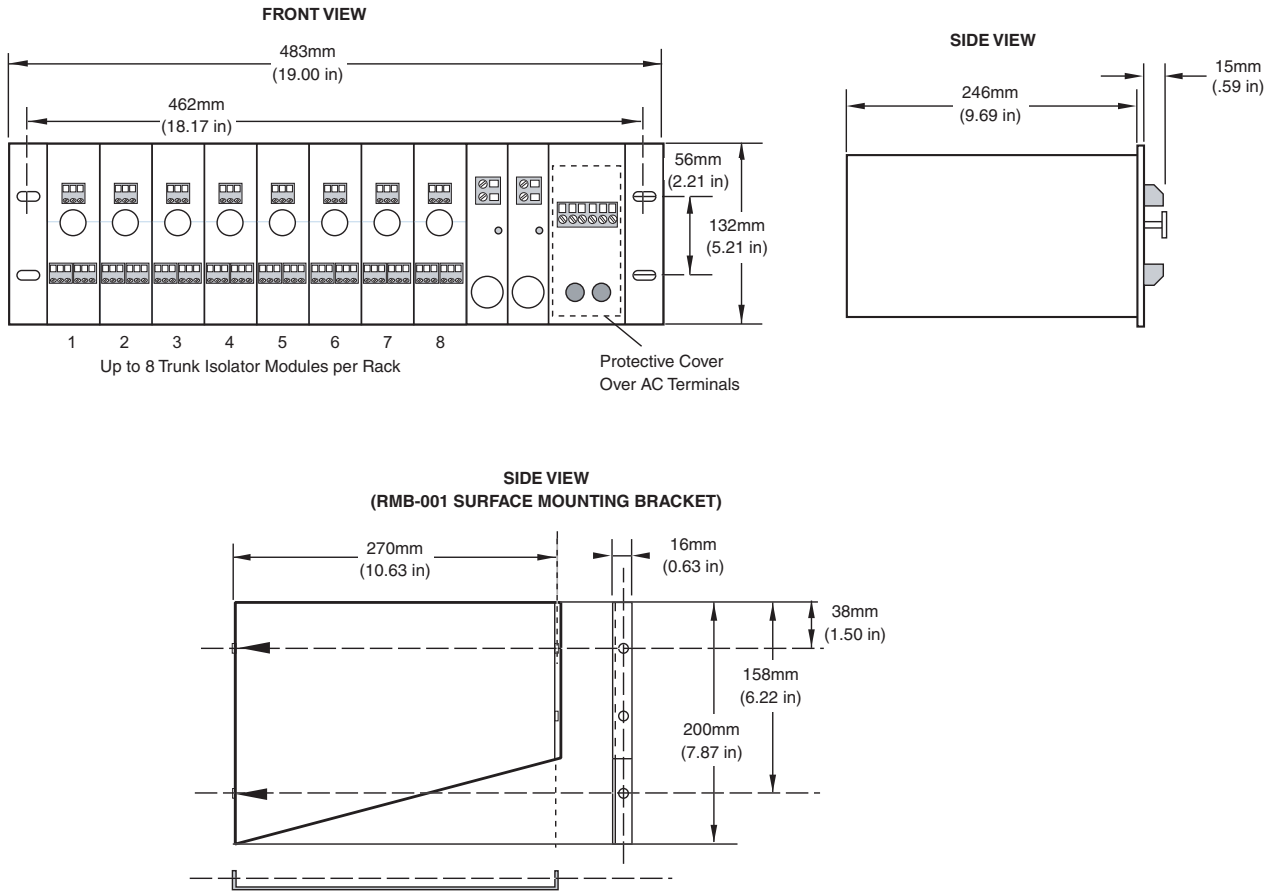
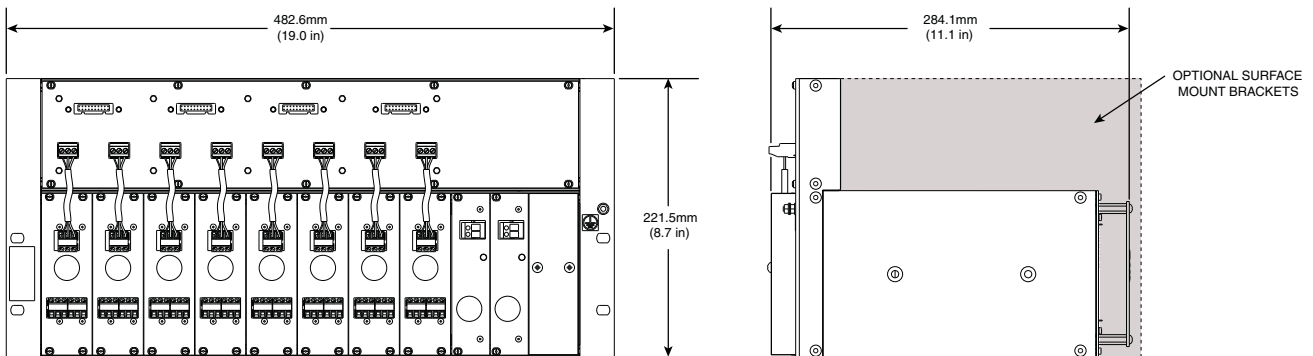

Figure 4. ROUTE-MASTER RM100 Fieldbus Power-Supply/Conditioner with Connector Panel. (RM110 Power Tray Combined with RM100 has same dimensions).



RM100

ROUTE-MASTER® Fieldbus System (Intrinsically-Safe Installations)

Figure 8. Electro-Polished Stainless Steel 316 Enclosure Installation Dimensions for 8- (RMA128) and 10-Spur (RMA12X) Device Couplers.

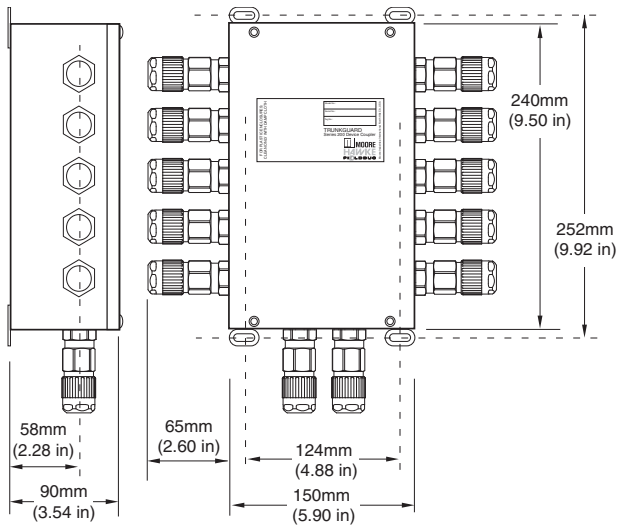

Figure 9. Stainless Steel 316 with E-Z Vertically Removable Lid and Bottom Entry Cable Gland Plate Installation Dimensions for 8-Spur (RMA148), 10-Spur (RMA14X) and 20-Spur (RMA14Y) Device Couplers.

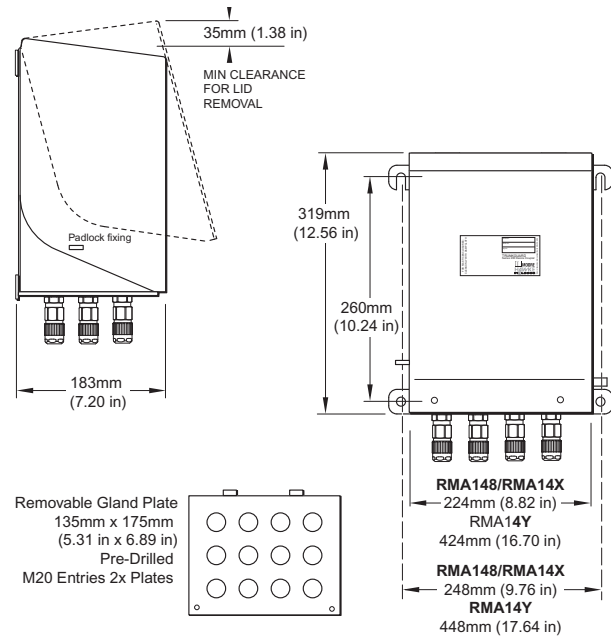
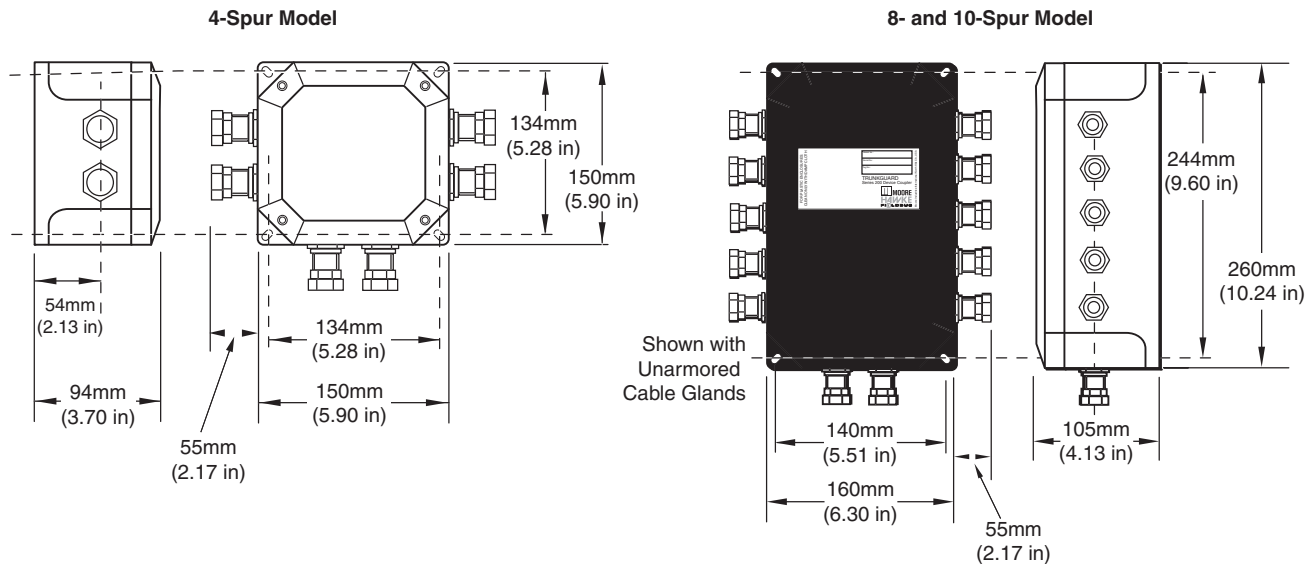

Figure 10. GRP (Glass-Reinforced Polyester) Enclosure Dimensions



United States • info@miinet.com
Tel: (818) 894-7111 • FAX: (818) 891-2816
Australia • sales@mooreind.com.au
Tel: (02) 8536-7200 • FAX: (02) 9525-7296

Belgium • info@mooreind.be
Tel: 03/448.10.18 • FAX: 03/440.17.97
The Netherlands • sales@mooreind.nl
Tel: (0)344-617971 • FAX: (0)344-615920

China • sales@mooreind.sh.cn
Tel: 86-21-62491499 • FAX: 86-21-62490635
United Kingdom • sales@mooreind.com
Tel: 01293 514488 • FAX: 01293 536852